

DESIGN SOLUTIONS

Journal of the Architectural Woodwork Institute

College
Museum
Library
Restaurant
Lobby



AWI

ARCHITECTURAL
WOODWORK
INSTITUTE



MILITARY LIBRARY HONORS HEROES & CITIZEN SOLDIERS.

The Pritzker Military Library in Chicago features more than 50,000 items including books, videos, periodicals, artwork, posters and rare military artifacts, along with 9,000 photographs from the American Civil War and the

Spanish-American War through the present day. Letters and journals from American soldiers and a sizable collection related to Winston Churchill are among the rare books in the library's growing special collection.



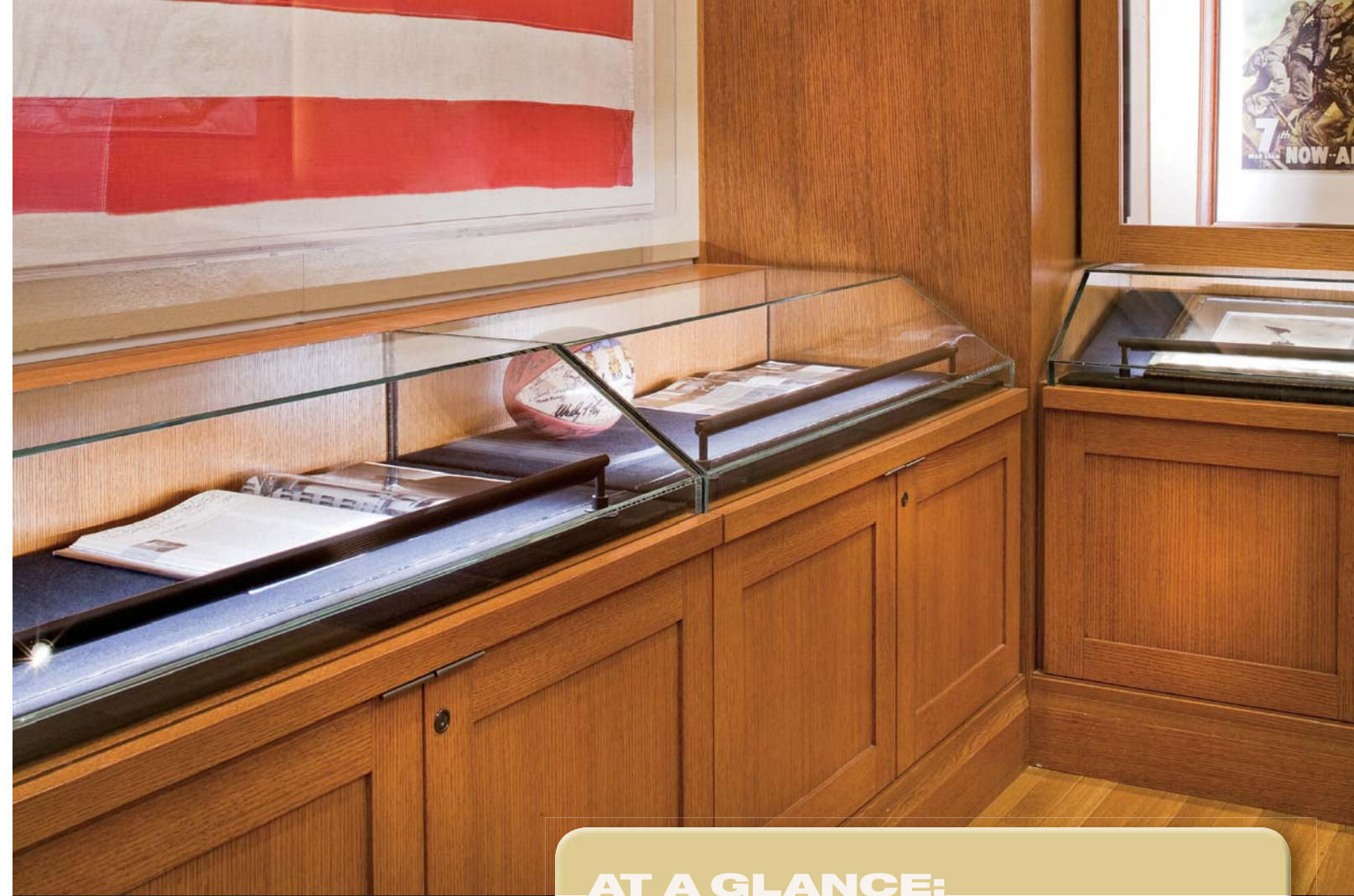

▲ **SPECIAL ARTIFACTS AND DOCUMENTS** are displayed in the elegant custom built, glass enclosed cases.

Founded by Colonel James Pritzker, IL ARNG (retired) in 2003 with about 7,500 books from his private collection, the library exhibits the story of the citizen soldier in American military history.

The new home for the library is a 1912, 16-story gothic style historic building on Michigan Avenue, across from the Art Institute of Chicago.

The building has been undergoing a major renovation and modernization on all floors. The Chicago office of TVS Design, architects that designed three floors, AWI member firm Bernhard Woodwork, Ltd., Northbrook, Illinois, along with the general contractor, collectively ensured that the building's historic value

remained while state-of-the-art technology and space management was incorporated into the design.

The traditional design aesthetic is in keeping with the historic building, including coffered ceilings, intricately fabricated wood paneling, built-in display cabinetry, paneled columns, extensive wood

trim and elements to create a space inviting to all types of people.

DESIGN STYLE

Prior to construction, the design team held a two-day workshop to ensure that the space design would meet the expectations of the library and its visitors.

AT A GLANCE:

AWI MANUFACTURING MEMBER:

Bernhard Woodwork, Ltd.

LOCATION: **Northbrook, Illinois**

FOUNDED: **1965**

SERVICES: **Commercial Architectural Woodwork, Retail Store Fixtures, Upscale Residential**

"While we're family rooted in tradition, we're hardly fixed on the past. Over the years we have embraced a variety of high technologies to deliver ever higher quality to our customers, faster than ever."

– Brain Lowry, Project Manager

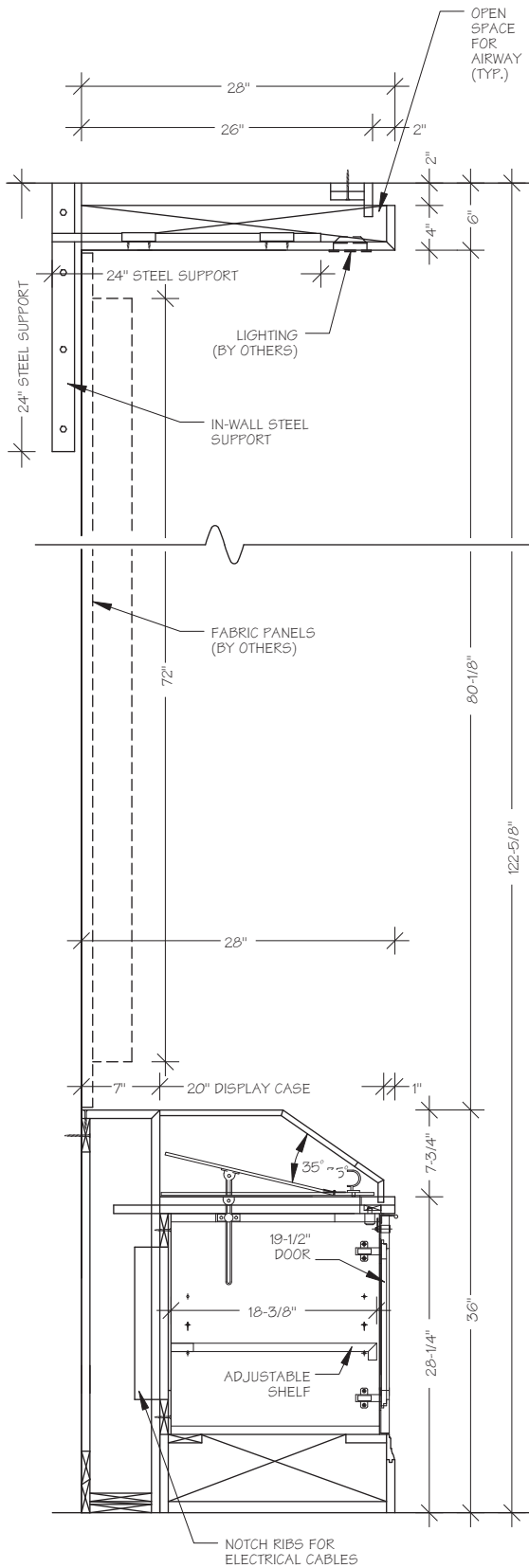

○ VERTICAL SECTION
Honor Display

The workshop involved participation from all stakeholders in the project as well as leaders of 10 cultural institutions across the country.

The 32,000 square foot project included library space for the books, artifacts, posters, correspondence and photographs, a 12-person lecture hall, support spaces, office spaces and reception desks.

“Our primary objective was to create an intuitive spatial flow and circulation to enhance the individual experiences of a diverse group of visitors,” explains Marc Adelman, AIA, CFM of TVS Design. “We wanted to deliver an elegant solution, rich in refined detail and craft to integrate into the historic fabric of the gothic style building.”

To facilitate events, the design team incorporated into its renovation design flexible galleries for traveling and permanent exhibits. A broadcast center is included to host a range of programs, as well as an oral history room to record past and present stories of visitors, and a special collections room for rare and out-of-print books, catering spaces for receptions, and a rare book receiving and archival area.





▲ THE COLLECTION OF OVER 50,000 BOOKS are safely encased in Red Oak bookcases.

RIFT RED OAK

Brian Lowry of Bernhard Woodwork reports that the primary wood and veneer specie used was rift Red Oak, with slip, balanced and end matched veneer

panels. The wood complements the Rookwood tile, ironwork and marble in the building.

“We helped in great detail to provide veneer layup direction with various veneer flitches to keep

color and grain detail consistent,” he says. “Additionally, we coordinated a very complicated hardware package for the doors throughout the project, and provided many hours of detailed sketches for the

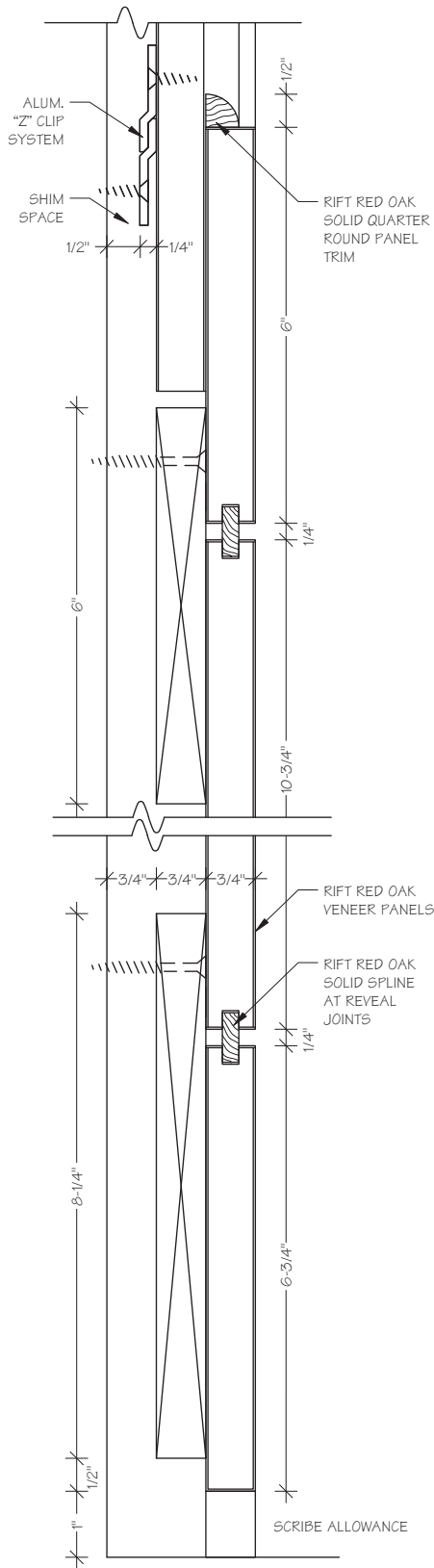

○ VERTICAL SECTION
Wall Panels

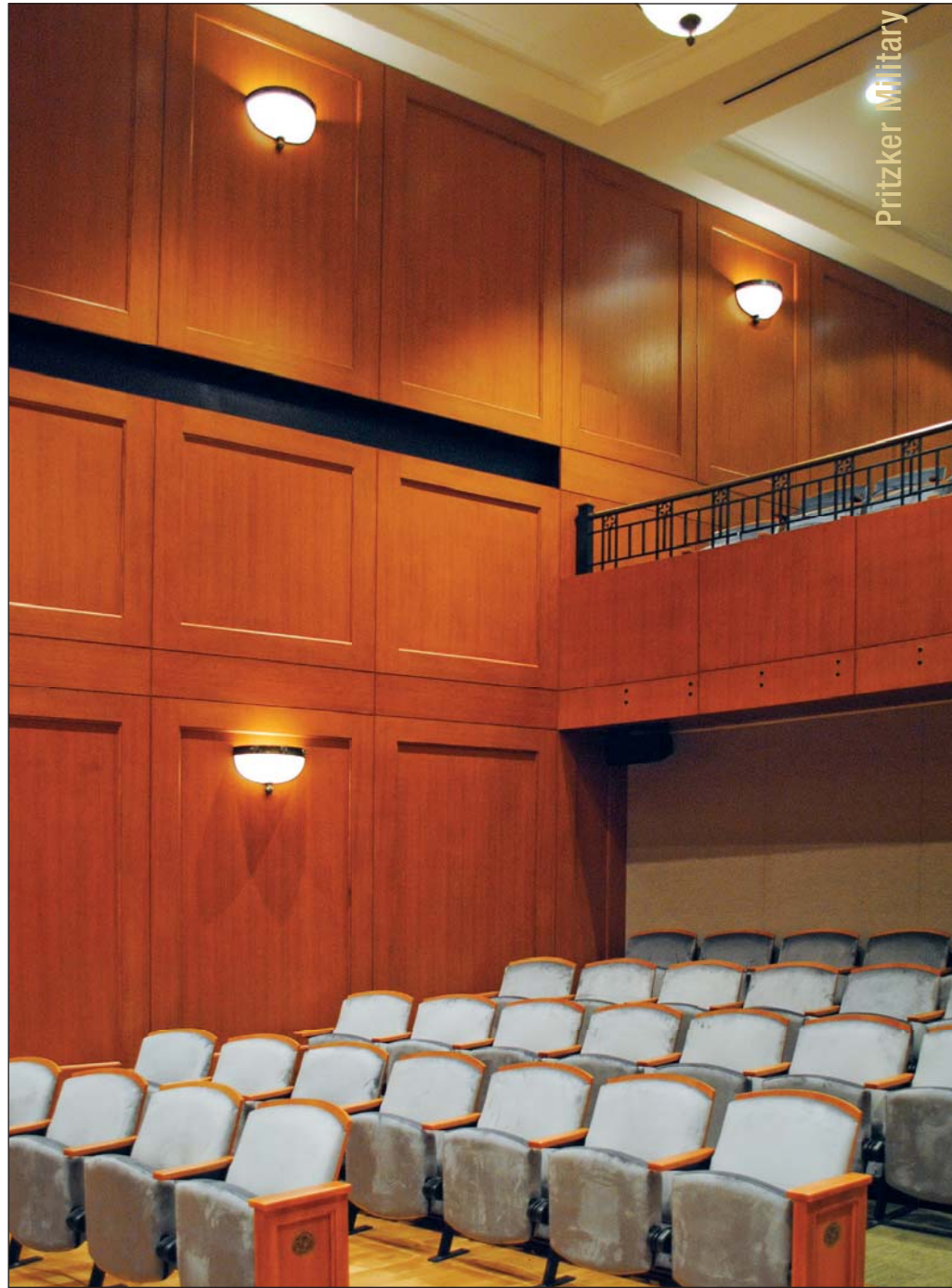

▲ PANELING ADDS ELEGANCE and solemnity to the lecture hall.

Medal of Honor display cabinetry and details required per ongoing field conditions.”

The selection of the type and color tone of spaces “was a challenge in which Bernhard, which

also did the installation,exceeded expectations,” says Edward Tracy, president of the military library.

The most intricate aspect of the project was the Medal of Honor display cabinetry, agree both the



▲ THE BEAUTIFUL CUSTOM DESIGNED and fabricated reception desk is accented by wood clad columns and Red Oak trim.

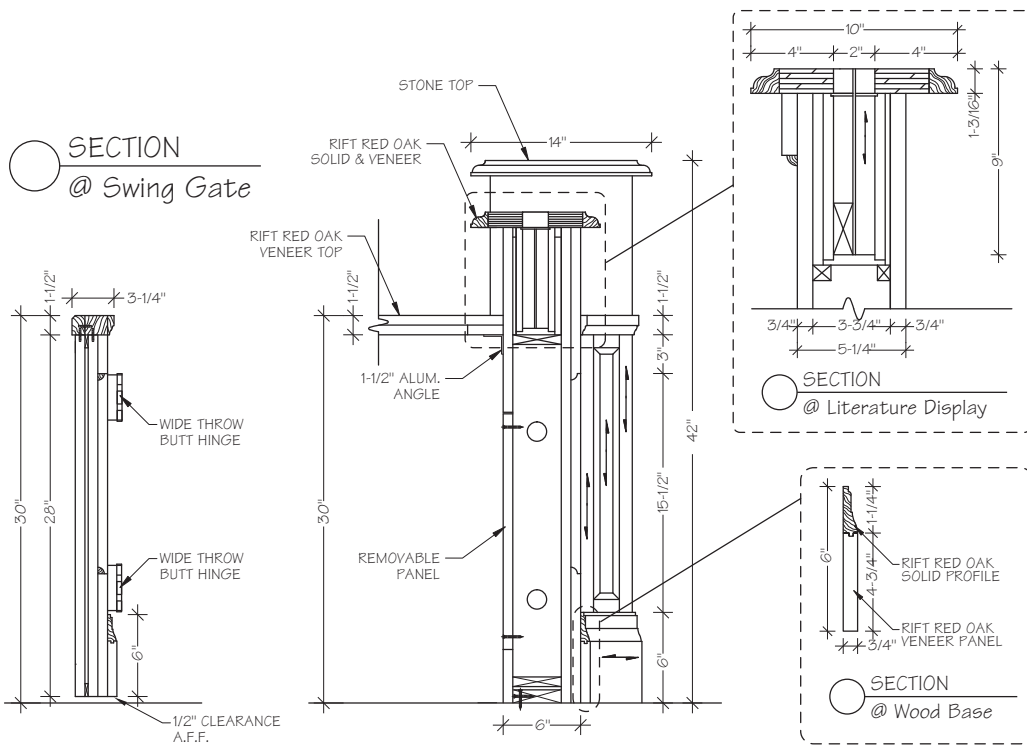

woodworkers and the designers. The display was created to accommodate a number of exhibits as well as provide security for our nation's highest honor.

"We designed lockable, glass pullout display drawers above lower cabinets to house significant, rare medals and artifacts," explains Lowry.

A number of challenging details were also tackled with integrating audio visual and HVAC requirements in the lecture hall with the full height wall paneling, he continues. Another

challenge was to match the interior window trim at the exterior perimeter to match original profile details including the screw heads and grommets. Bronze screws and grommets were chemically treated to match the original finish.

COLLABORATIVE ENVIRONMENT

“We had a very collaborative relationship with Bernhard Woodwork,” recalls Adelman.

“Brian Lowry, project manager, helped work out a number of challenging details regarding design intent and field conditions.”

“As architectural woodworkers we welcome the opportunity to help coordinate with architects and designers in all areas whether it be choosing various veneers to use, layup patterns, integrating of lighting, joinery details for woodwork constructions, and issues that are foreseen from the start,” says Lowry.

Since 2003 the library has produced more than 300 programs including interviews with Medal of Honor recipients. Programs are webcast live on the library’s website, archived for later viewing and available as podcasts. The new facility has the capacity to continue to expand the library’s offerings which have been broadcast on the local PBS affiliate for more than three years. 📺

Project:	Pritzker Military Library	Chicago, IL
Project Owner:	Tawani Foundation	Chicago, IL
Woodworker:	Bernhard Woodwork, Ltd.	Northbrook, IL
Architect:	TVS Design	Chicago, IL
General Contractor:	Bulley & Andrews LLC	Chicago, IL
Photographer:	Brian Gassel	Atlanta, GA

▼ A CLOSE-UP OF THE DISPLAY CABINETS shows off the details and consistency of grain and color.

